

60 min

«Achtung! Im Falle einer Reklamation bitte unbedingt das entsprechende Teil auf der der „Explosionszeichnung“ (Seite 2) einkreisen und diese Seite zur Verfügung stellen! Dies sichert eine reibungslose Abwicklung»

ASSEMBLY INSTRUCTION

Ax36



Bx36



Cx16



Dx8



Ex12



Fx50



Gx2



Hx1

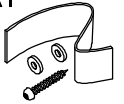

Jx12



Ø3,5x15

Kx5



Ø3,5x20

Lx2



Mx6



Nx6

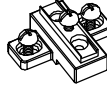

Ox2



!Achtung !Diese Beschläge befinden sich im Kollo mit den Türen!

!Achtung die Teile 14, 15, 16, 17 sind nur im Grundregal enthalten!

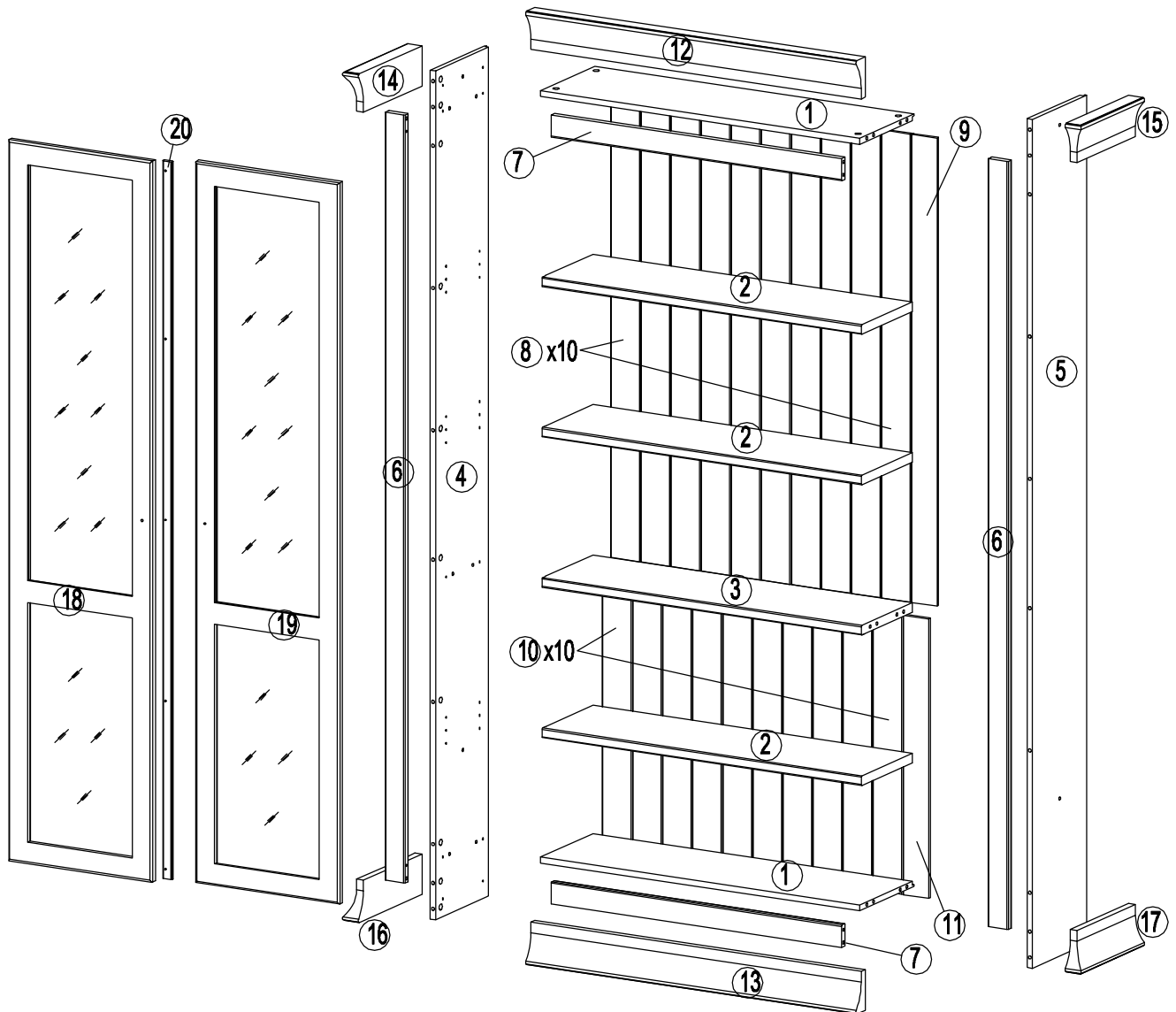

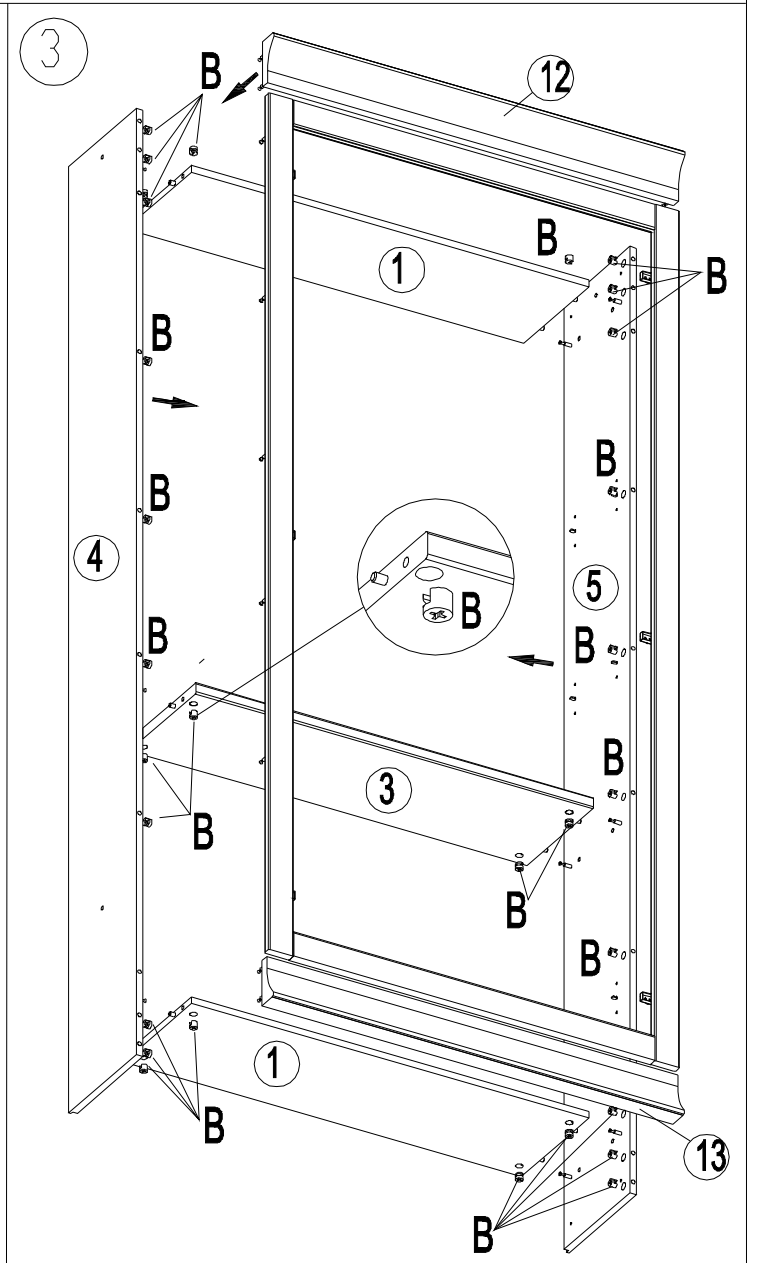
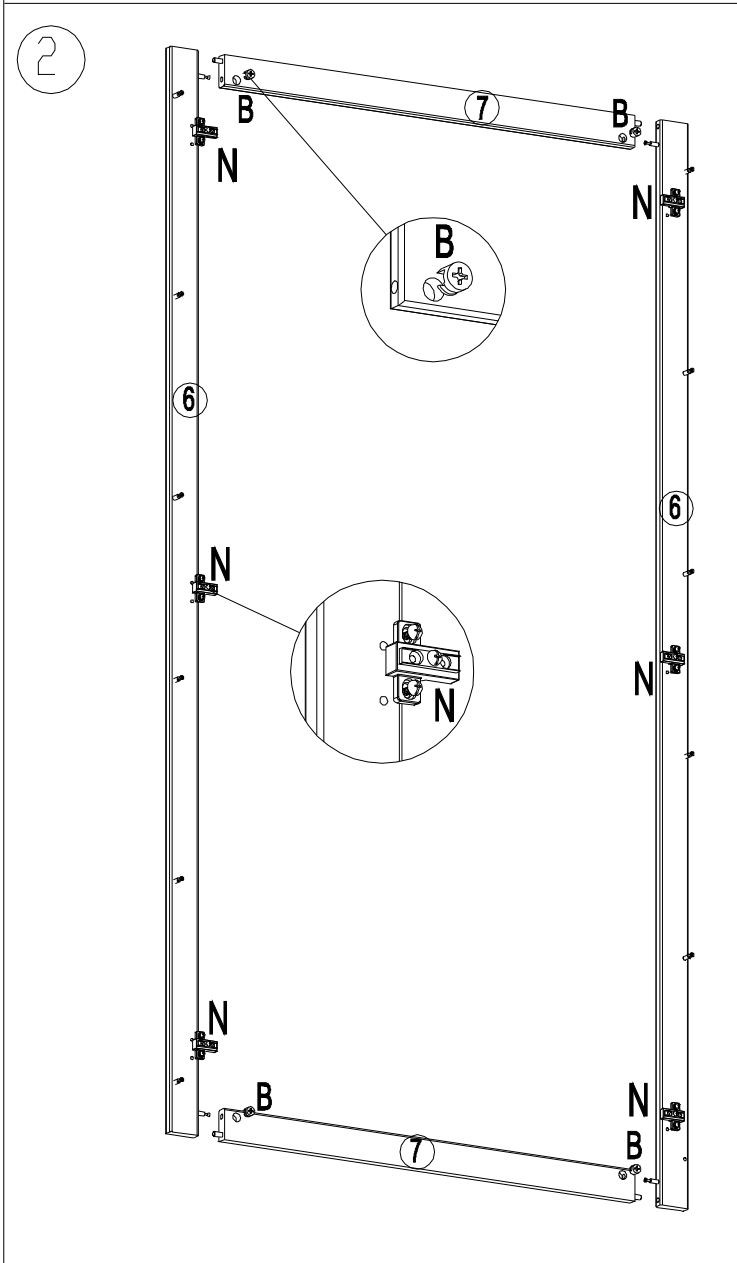
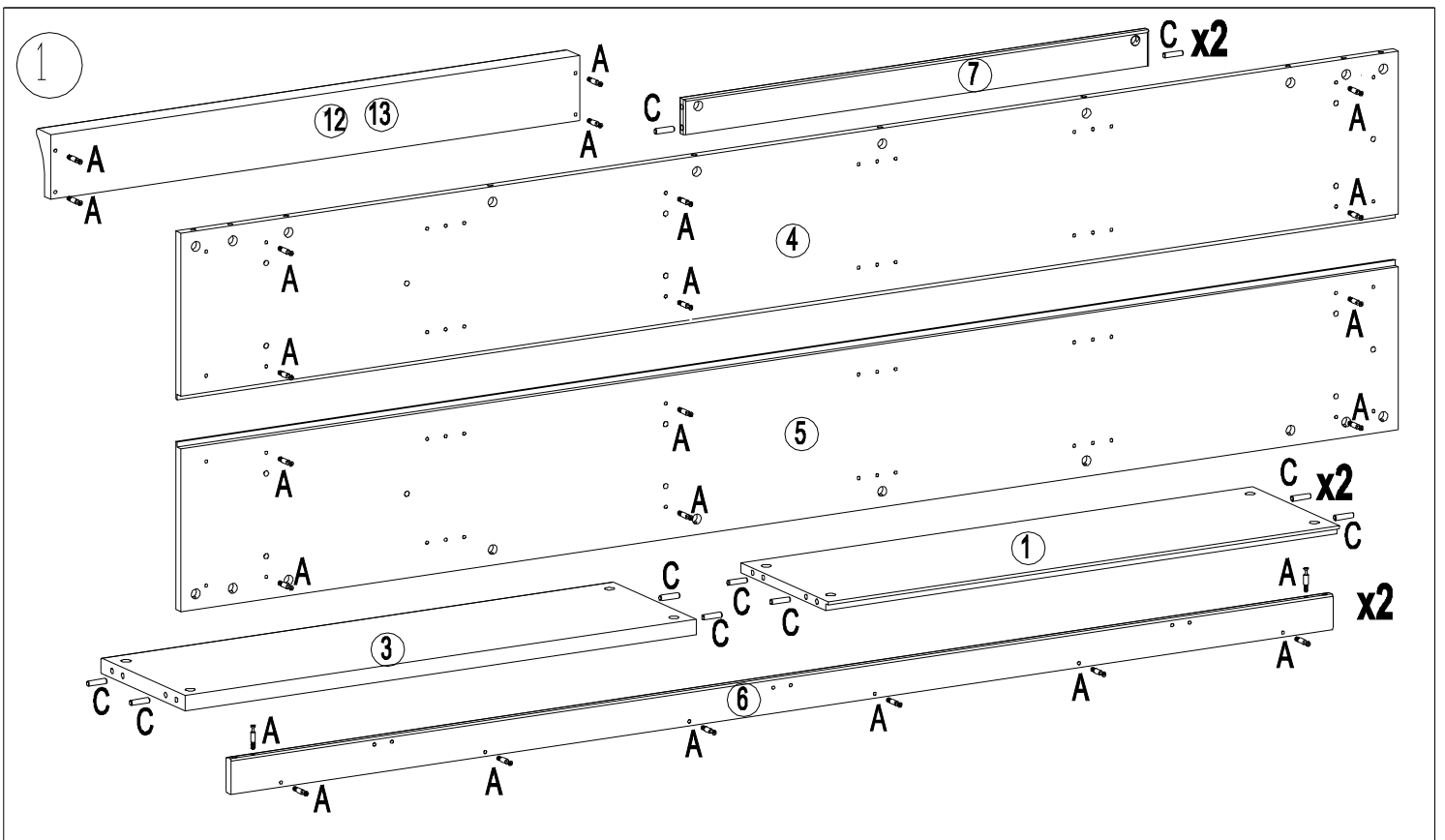

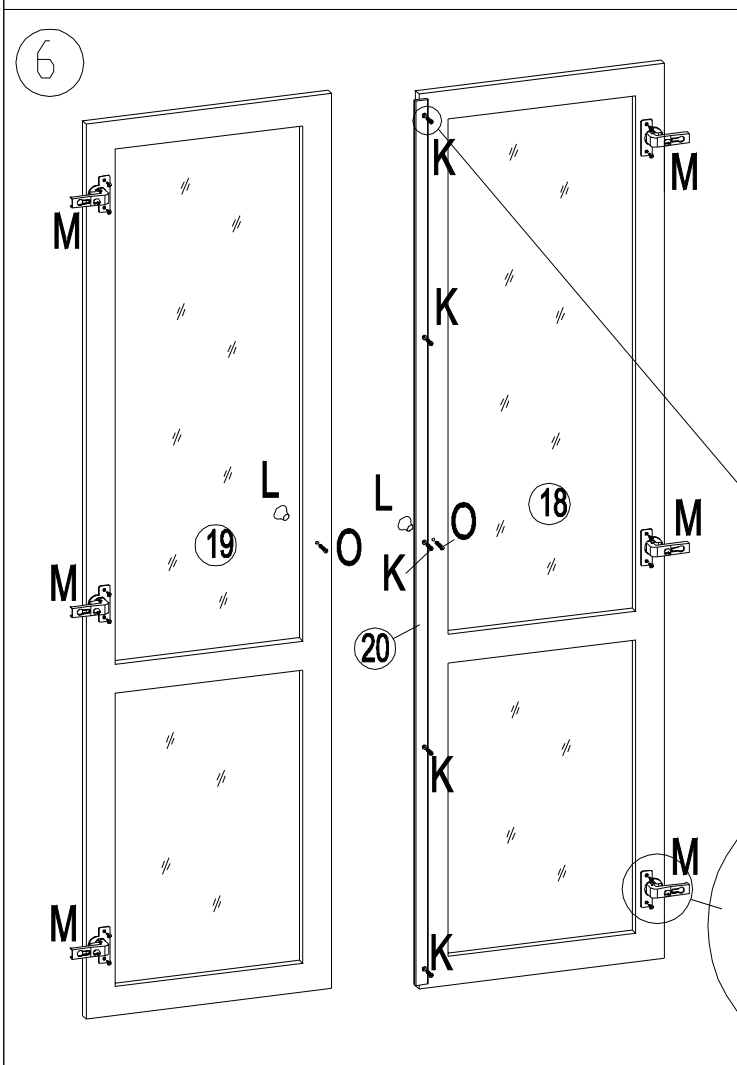
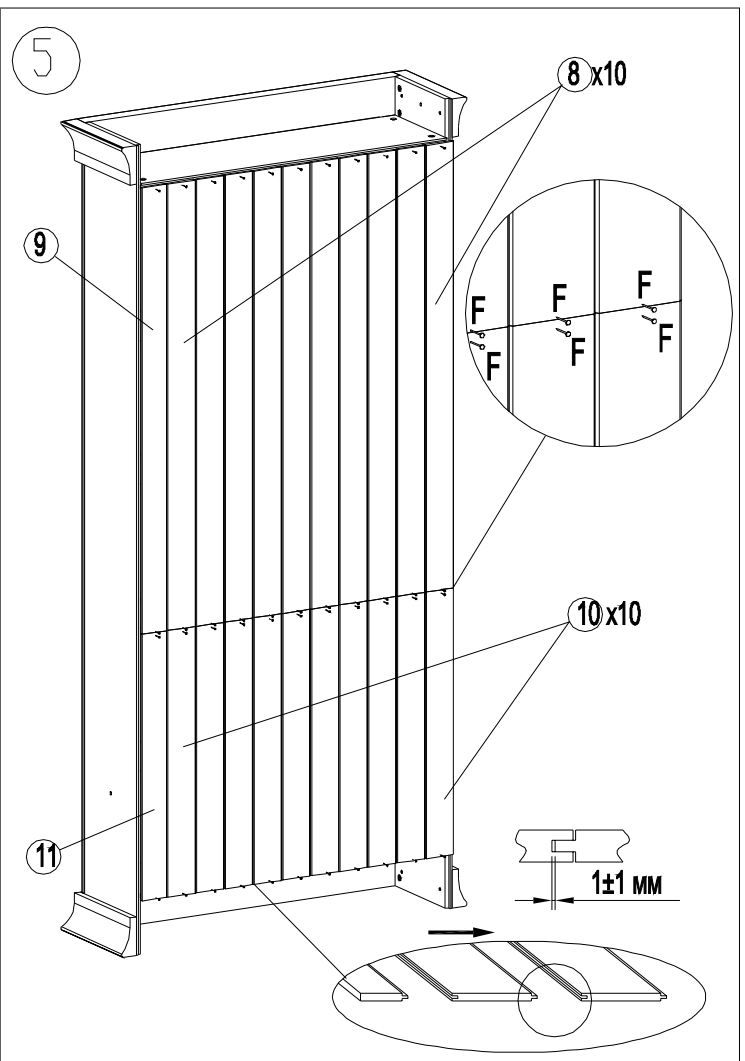
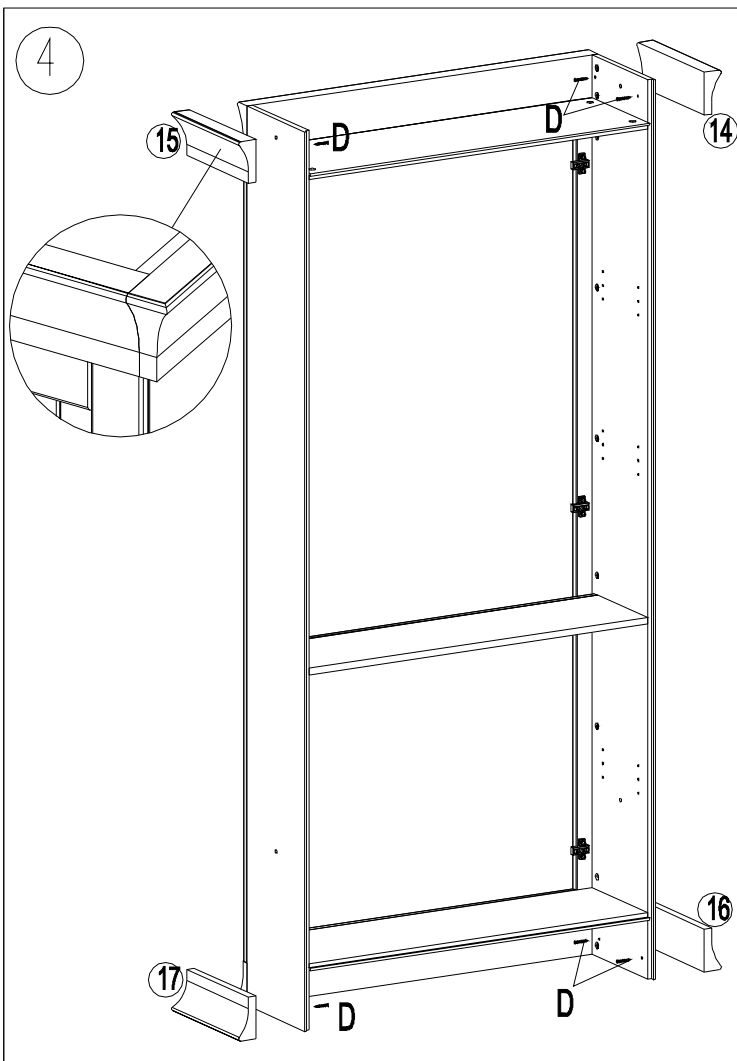

!ACHTUNG! Die Rückwand muss über Nute und Feder vermittelt und angepasst montiert werden!

!ACHTUNG! Die Bretter für die Rückwand nicht fest zusammenfügen. Erst über die gesamte Fläche auslegen und dann befestigen!

